

USN

--	--	--	--	--	--	--	--	--	--	--	--

18AU53

Fifth Semester B.E. Degree Examination, July/August 2022
Design of Machine Elements – I

Time: 3 hrs.

Max. Marks: 100

- Note:** 1. Answer any FIVE full questions, choosing ONE full question from each module.
2. Use of machine design data hand book is permitted.

Module-1

- 1 a. Draw the stress – strain diagram for a ductile material and show the salient points on them. (05 Marks)
- b. A point in a structural member subjected to plane stress is shown in Fig.Q1(b). Determine :
 - i) Normal and tangential stress intensities on plane EF inclined at an angle of 30°
 - ii) Principal stresses and their direction
 - iii) Maximum shear stress and the direction of the planes on which it occurs.

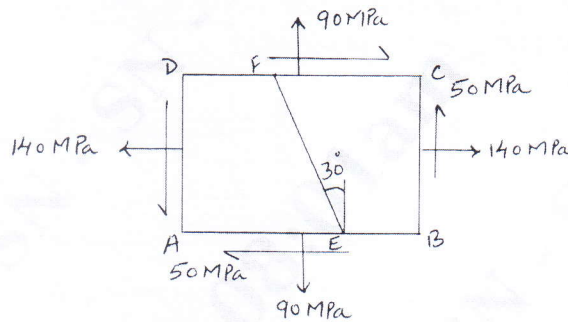

Fig.1(b)

(15 Marks)

OR

- 2 a. Explain the following theories of failure
 - i) Maximum principal stress theory
 - ii) Maximum shear stress theory. (06 Marks)
- b. A mild steel bracket shown in Fig.Q2(b) is subjected to a pull of 10kN. The bracket has a rectangular cross-section whose depth is twice the width. If the allowable stress for the material is 80N/mm^2 , determine the c/s(cross section) of the bracket.

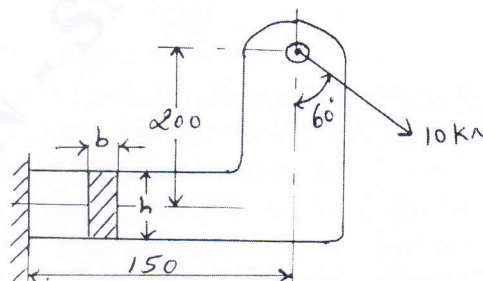

Fig.Q2(b)

(14 Marks)

Important Note : 1. On completing your answers, compulsorily draw diagonal cross lines on the remaining blank pages.
2. Any revealing of identification, appeal to evaluator and /or equations written eg, 42+8 = 50, will be treated as malpractice.

Module-2

- 3 a. Define stress concentration factor and explain the methods of reducing stress concentration. (10 Marks)
- b. Find the value of the maximum stress induced on the fillet if the stress concentration factor for the filleted flat box shown in Fig.Q3(b) having a $\frac{D}{d}$ ratio of 1.2. Also determine the factor of safety if the flat box is made of steel having a yield stress of 640N/mm^2 . Thickness of the box is 25mm.

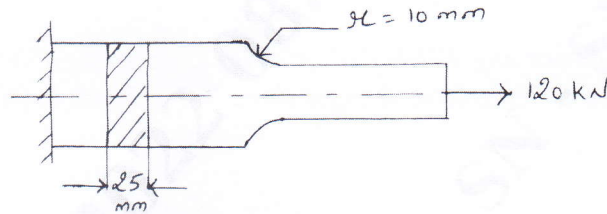

Fig.Q3(b)

(10 Marks)

OR

- 4 a. Derive the Goodman equation for designing the member subjected to the fatigue loading. (10 Marks)
- b. A cantilever beam shown in Fig.Q4(b) is subjected to load variation for $-F$ to $3F$. Determine the maximum load that this member can withstand for an infinite life, using a factor of safety 2. The material of the beam is SAE 1025, water quenched steel ($\sigma_u = 620.8\text{MPa}$, $\sigma_y = 400.1\text{MPa}$, $\sigma_{-1} = 345.2\text{MPa}$).

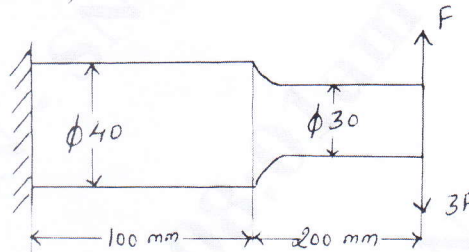

Fig.Q4(b)

(10 Marks)

Module-3

- 5 a. Design a sleeve type cotter joint to connect two tie rods subjected to an axial pull of 60kN. The allowable stress of C30 material used for the rods and cotters are $\sigma_t = 65\text{N/mm}^2$, $\sigma_c = 75\text{N/mm}^2$, $\tau = 35\text{N/mm}^2$. Cast steel used for the sleeve has the allowable stresses $\sigma_t = 70\text{N/mm}^2$, $\sigma_c = 110\text{N/mm}^2$ and $\tau = 45\text{N/mm}^2$. (10 Marks)
- b. Design a sleeve coupling to transmit 10KW at 200rpm. The allowable values of shear stress and compressive stress for the shaft and key material may be taken as 60N/mm^2 and 130N/mm^2 respectively. Use allowable shear stress in cast iron sleeve equal to 15N/mm^2 . (10 Marks)

OR

- 6 A horizontal piece of commercial shafting is supported by two bearings 1.5m apart. A keyed gear 20° involutes and 175mm in diameter is located 400mm to the left of the right bearing and is driven by a gear directly behind it. A 600mm diameter pulley is keyed to the shaft 600mm to the right of the left bearing and drives a pulley with a horizontal belt directly behind it. The tension ratio of the belt is 3 to 1, with the slack side on top. The drive transmits 45KW at 330rpm. Take $K_b = K_t = 1.5$. Calculate the necessary diameter of the shaft and angular deflection in degrees. Use allowable shear stress 40 MPa and $G = 80 \times 10^9\text{N/mm}^2$. (20 Marks)

Module-4

- 7 a. Explain the failure of riveted joints. (10 Marks)
 b. Determine the load carrying capacity for a riveted joint shown in Fig.Q7(b). The allowable stresses in 25mm diameter rivets are 100N/mm^2 in tension and 50N/mm^2 in shear.

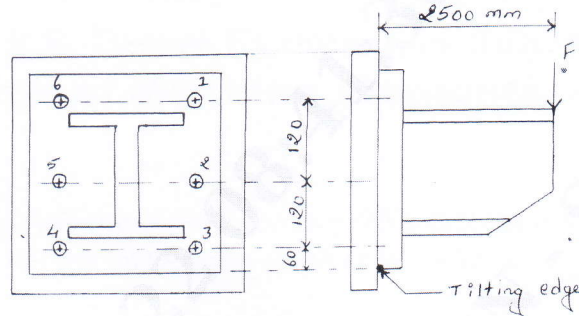

Fig.Q7(b)

(10 Marks)

OR

- 8 a. Explain the types of welded joints. (08 Marks)
 b. A welded connection of steel plates as shown in Fig.Q8(b) is subjected to an eccentric load of 10kN. Determine the throat dimension of weld if the permissible stress is limited to 95N/mm^2 . Assume static conditions.

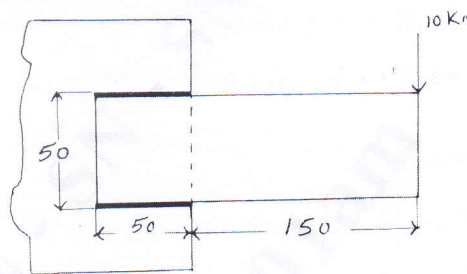

Fig.Q8(b)

(12 Marks)

Module-5

- 9 a. Derive an expression for torque required to lift the load on square threaded screw. (08 Marks)
 b. A weight of 500kN is raised at a speed of 6m/min by two screw rods with square threads of 50×8 cut on them. The two screw rods are driven through bevel gear drives by a motor, determine :
 i) The torque required to raise the load
 ii) The speed of rotation of the screw rod assuming the threads are of double start
 iii) The maximum stresses induced on the cross – section of the screw rod
 iv) The efficiency of screw drive
 v) The length of nuts for the purpose of supporting the load
 vi) Check for overhaul. (12 Marks)

OR

- 10 a. With neat sketch explain the threaded screw terminology. (10 Marks)
 b. A cylinder head is fastened to the cylinder of an air compressor using 8 numbers to bolt. The cylinder core diameter is 300mm. The pressure inside the cylinder varies from zero to a maximum pressure of 1.5N/mm^2 . The stresses for the bolt material may be taken as $\sigma_u = 500\text{N/mm}^2$, $\sigma_y = 300\text{N/mm}^2$, $\sigma_{-1} = 240\text{N/mm}^2$. The bolts are tightened with an initial preload of 1.5 times the steam load. A copper asbestos gasket is used to make the joint leak proof. Assuming a factor of safety of 2.5, find the size of bolt required. Neglect stress concentration effect on the bolt and size effect. (10 Marks)
